

USB

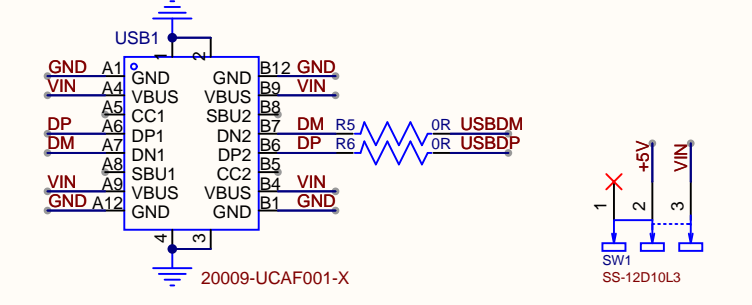

5V To 3V3

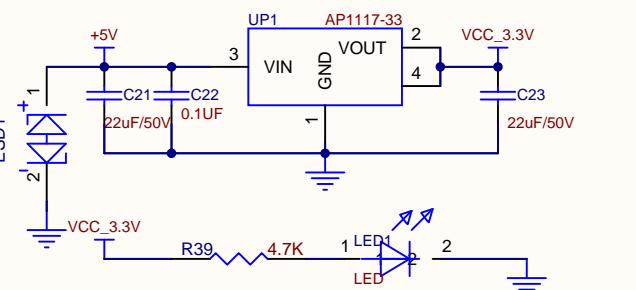

SD-CARD

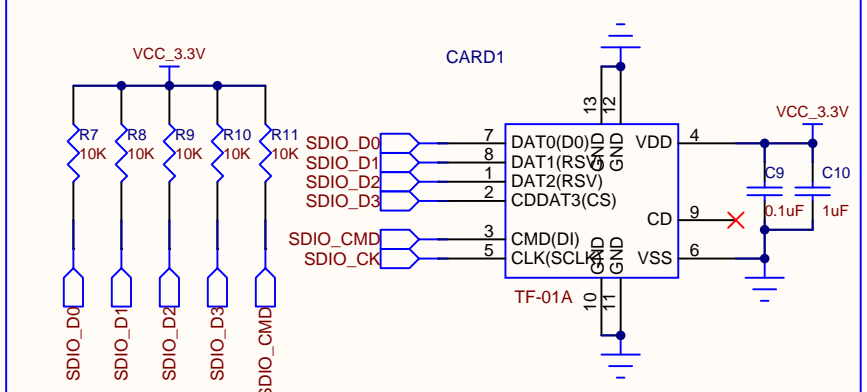

JTAG&SWD

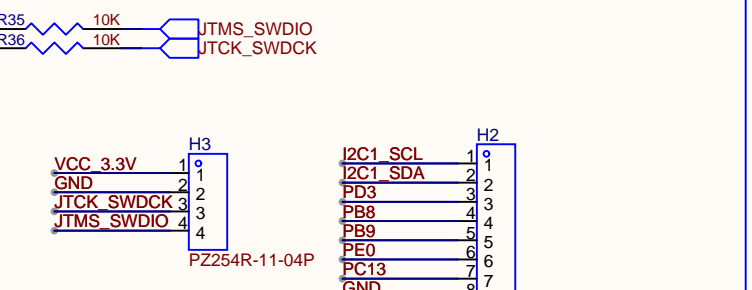

7 Inch VGH,VHL

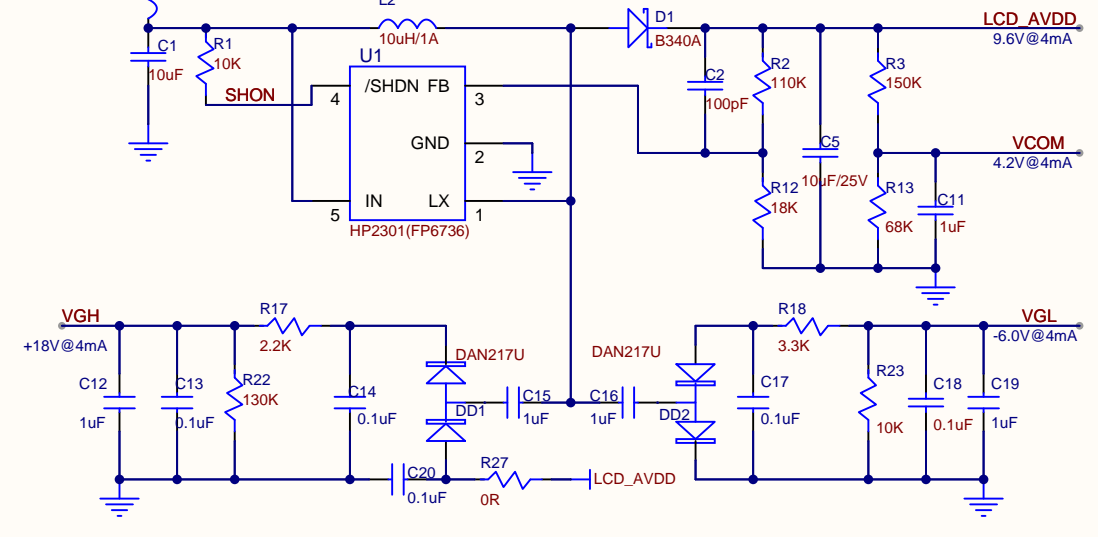

LCD-Backlight

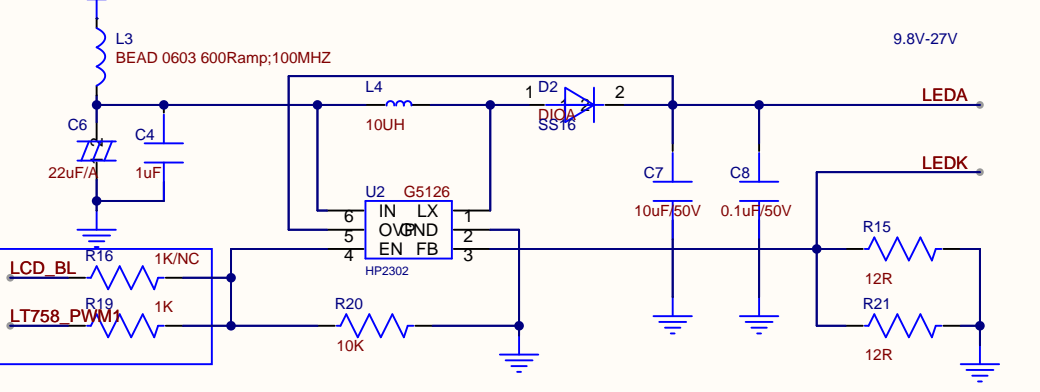

CTP

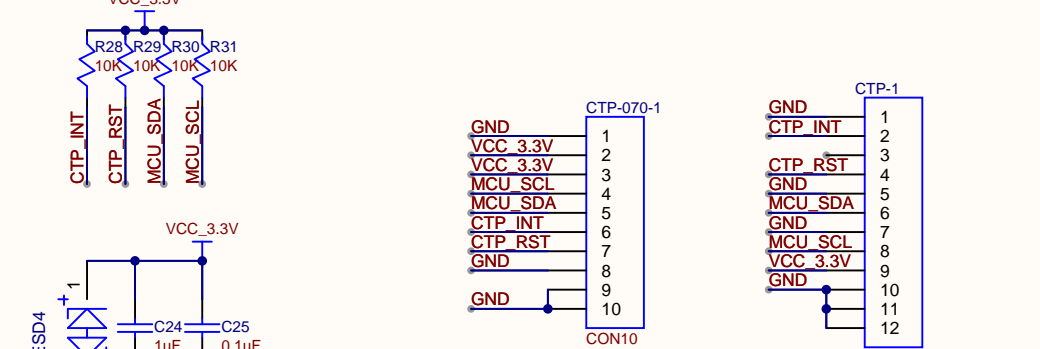

5 Inch

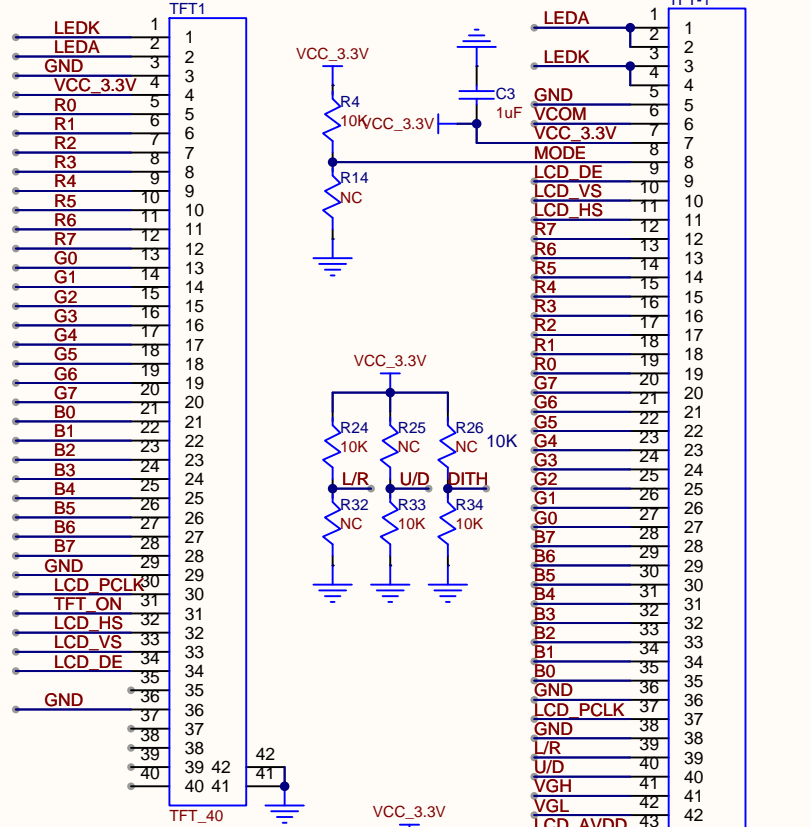

7 Inch

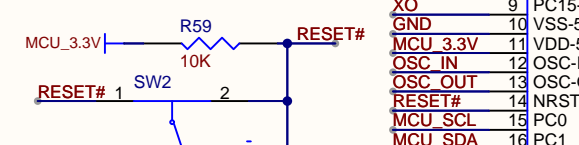
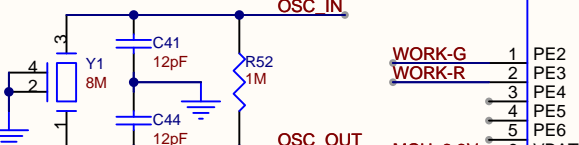
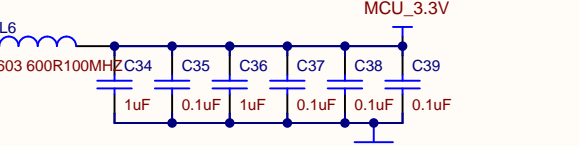
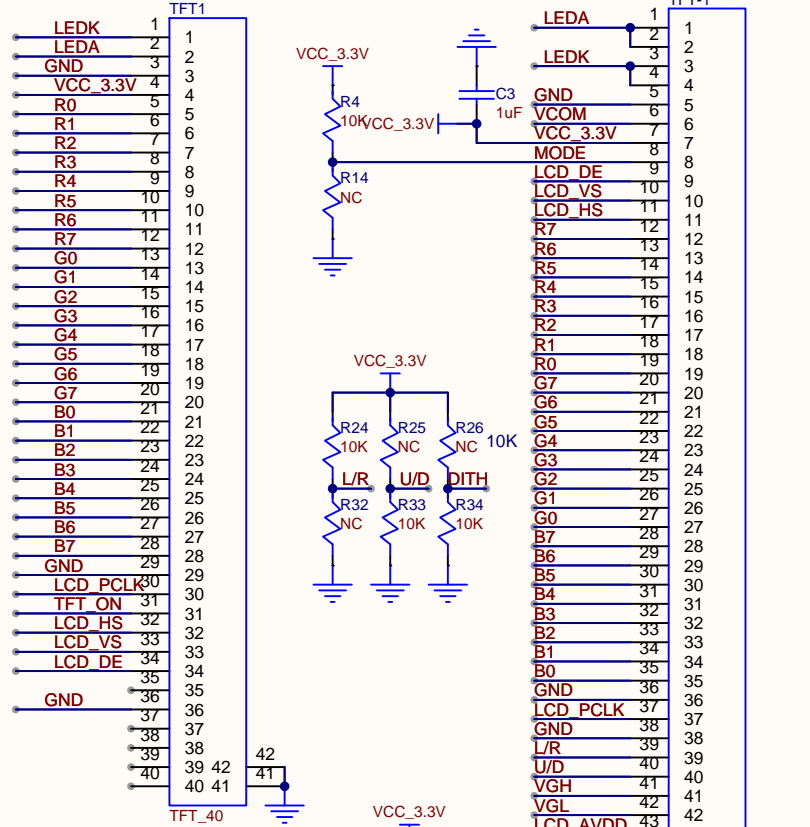

FLASH

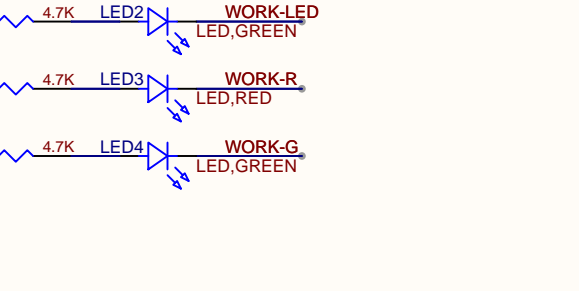
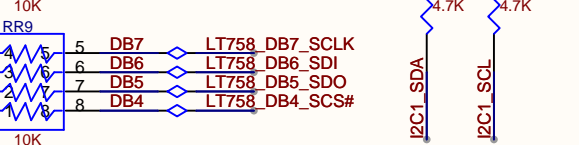
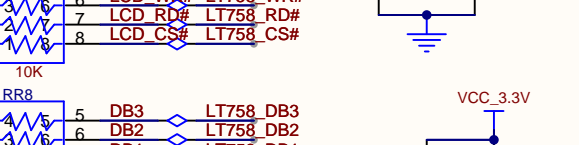
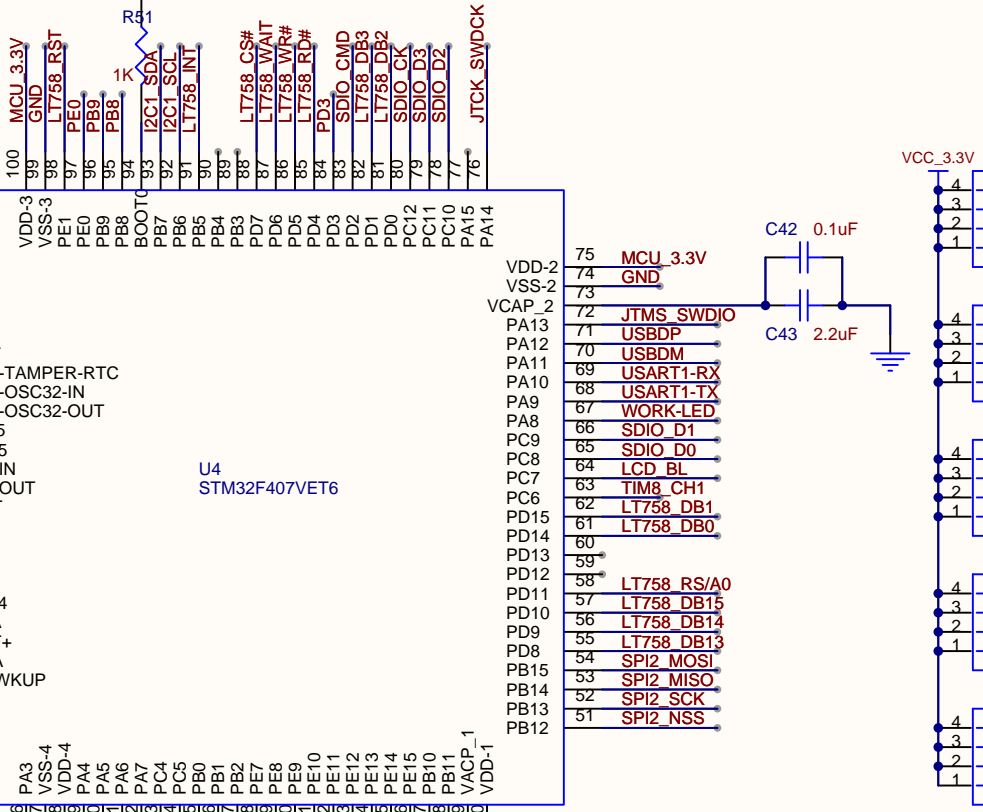
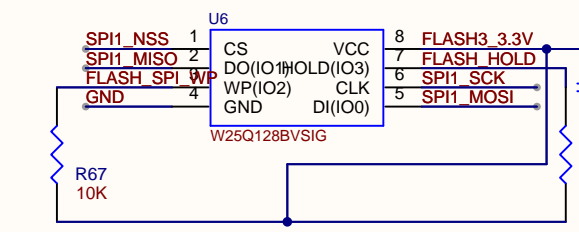

LT7586

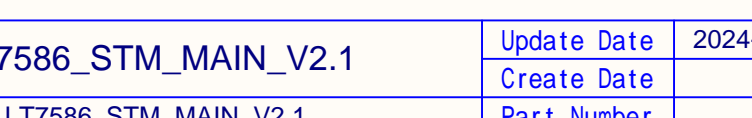
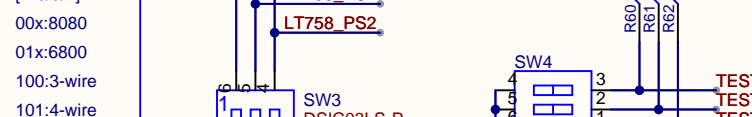
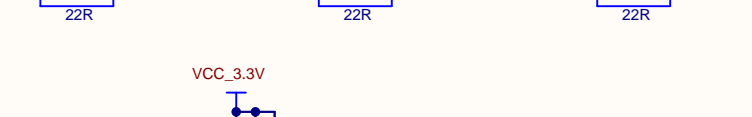
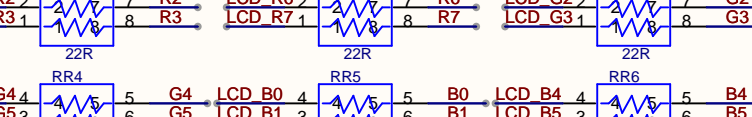
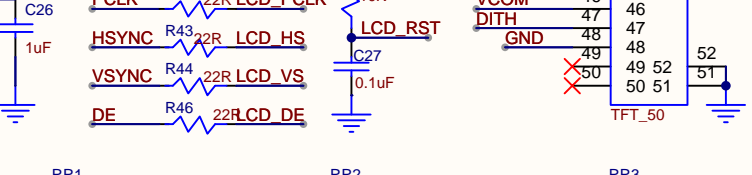
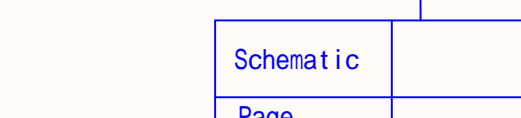
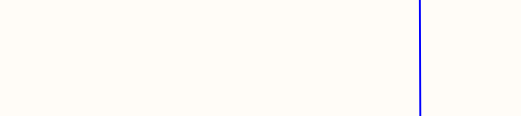
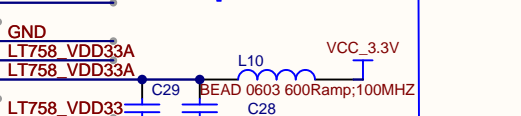
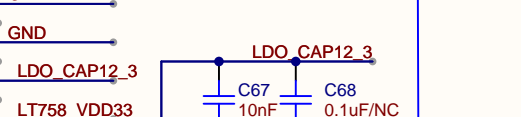
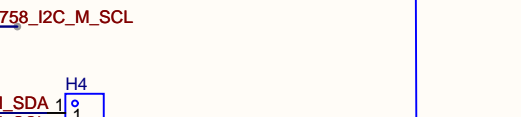
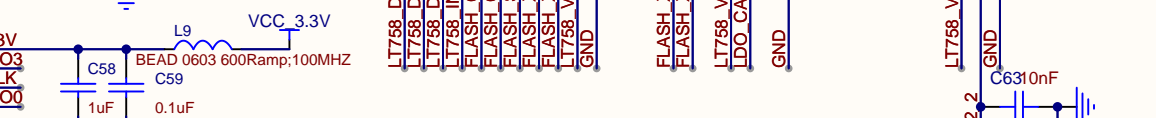
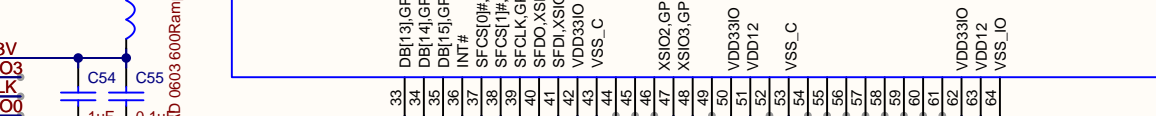
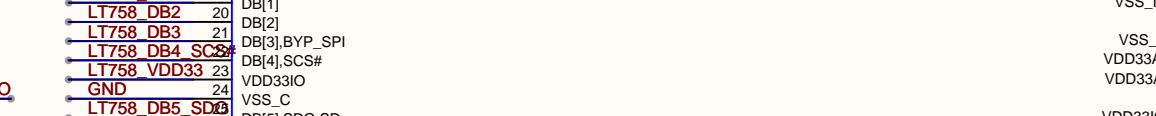
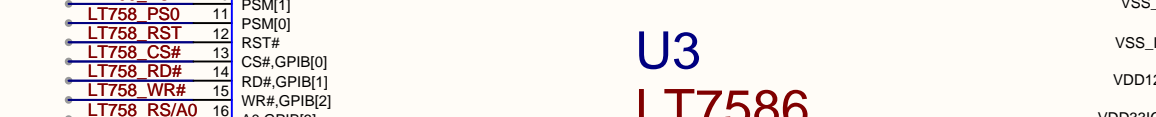
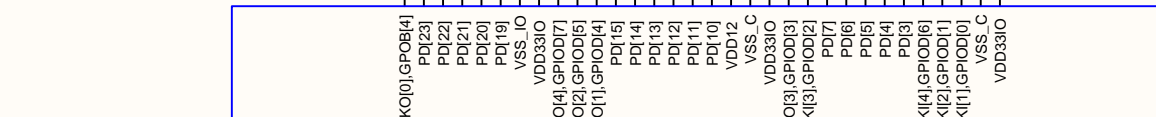
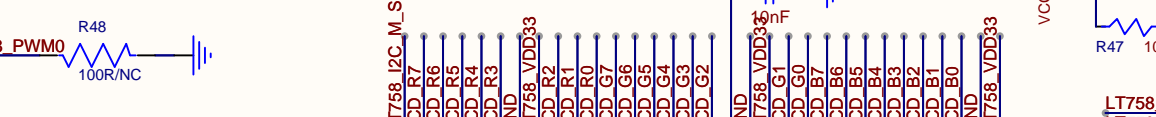
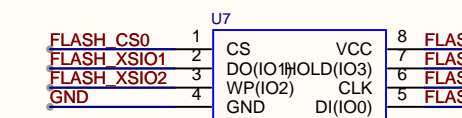
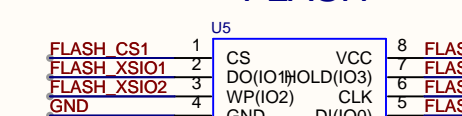
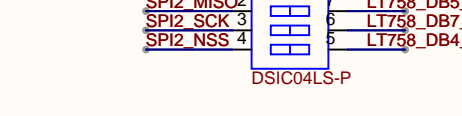
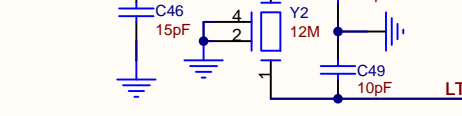
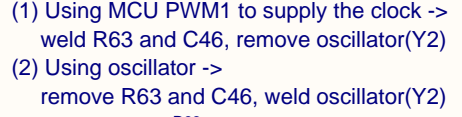
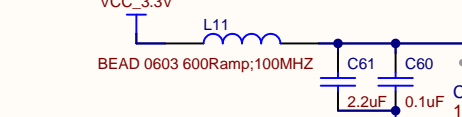
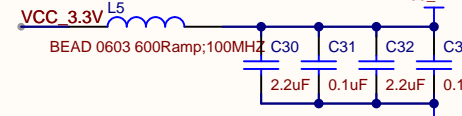

Schematic	LT7586_STM_MAIN_V2.1	Update Date	2024-10-08
Page	LT7586_STM_MAIN_V2.1	Create Date	
Drawn		Part Number	
Reviewed			

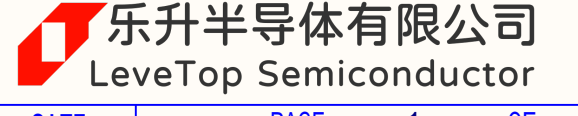

VER	SIZE	PAGE	1	OF	1
V2.0					
Levetop Semiconductor.					